

Block Placement with Symmetry Constraints based on the O-tree Non-Slicing Representation

Yingxin Pang[†] Florin Balasa[‡] Koen Lampaert[†] Chung-Kuan Cheng[†]

[†]Dept. of CSE, University of California, San Diego, La Jolla, CA 92093

[‡]Dept. of EECS, University of Illinois, Chicago, Chicago, IL 60607-7053

[†]Conexant Systems Inc., 4311 Jamboree Road, Newport Beach, CA 92660

ABSTRACT

The ordered tree (O-tree) representation has recently gained much interest in layout design automation. Different from previous topological representations of non-slicing floorplans, the O-tree representation is simpler, needs linear computation effort to generate a corresponding layout, and exhibits a smaller upper-bound of possible configurations. This paper addresses the problem of handling symmetry constraints in the context of the O-tree representation. This problem arises in analog placement, where symmetry is often used to match layout-induced parasitics and to balance thermal couplings in differential circuits. The good performance of our placement tool dealing with several analog designs taken from industry proves the effectiveness of our technique.

1. INTRODUCTION

The ability of placement tools to optimize complex layout-related objectives, while having the flexibility to handle a large variety of specific constraints, is crucial in order to automatically produce high-quality layouts in terms of density and electrical performance. In device-level analog placement dealing with symmetry constraints is essential, as analog circuits use very often differential architectures based on electrically symmetric networks. Symmetry is widely used in analog layout to match interconnection parasitics and device parameters, or to balance thermal effects.

The issue of symmetry has been addressed so far in the context of two distinct classes of analog placement solutions. The first class of tools, exploring the absolute representation of placement configurations with simulated annealing algorithms, has proven to be successful when dealing with industrial examples [2],[5-7]. However, they may converge slowly, due to the huge size of the search space which contains also infeasible placement configurations (as cells are allowed to overlap). In addition, the tuning of these tools is usually difficult, requiring a significant amount of testing effort.

The second class of solutions employs topological representations of placement configurations, where cell positions are specified based on encoded topological relations. In the ILAC system [9],

This work is supported in part by grants from NSF Project MIP-9529077 and the California MICRO program

Permission to make digital or hard copies of all or part of this work for personal or classroom use is granted without fee provided that copies are not made or distributed for profit or commercial advantage and that copies bear this notice and the full citation on the first page. To copy otherwise, to republish, to post on servers or to redistribute to lists, requires prior specific permission and/or a fee.

DAC 2000, Los Angeles, California
©2000 ACM 1-58113-187-9/00/0006..\$5.00

symmetry is handled in a slicing floorplan model. Recently, several non-slicing topological representations have been proposed. Symmetry constraints can be efficiently handled within the sequence-pair representation as shown in [1].

The O-tree representation[4] has recently gained an increasing interest: different from the other topological representations, O-tree needs a smaller amount of encoding storage and linear time computation effort to generate each placement configuration. In addition, the upper-bound of possible encodings is smaller, which entails a reduced representation redundancy. These important advantages are strong incentives to address the symmetry constrained placement problem in the context of the O-tree representation.

In this paper, we present a novel placement technique based on the O-tree representation, in the presence of positioning and symmetry constraints. The good performance of our placement tool when dealing with several analog designs taken from industry proves the effectiveness of our approach.

2. BRIEF OVERVIEW OF THE O-TREE REPRESENTATION

An n -node O-tree is a tree with $n+1$ nodes encoded by (T, π) , where T is a $2n$ -bit string that identifies the branching structure of the tree, and π is a permutation of the n node labels (excluding the root). When traversing the tree, we write a '0' for descending an edge and a '1' for subsequently ascending that edge. Given the 7-node O-tree in Figure 1(a), we can represent it as $T=0010110010110011$, $\pi=abcdefgh$.

An O-tree where nodes represent rectangular blocks imposes both horizontal and vertical positioning constraints:

- (a) each parent block must be placed to the left of its children;
- (b) if two blocks are overlapping along their x-coordinate projection, the block having a higher index in permutation π must be placed on top of the one having a lower index.

Figure 1(b) displays the minimum area placement of the O-tree(a).

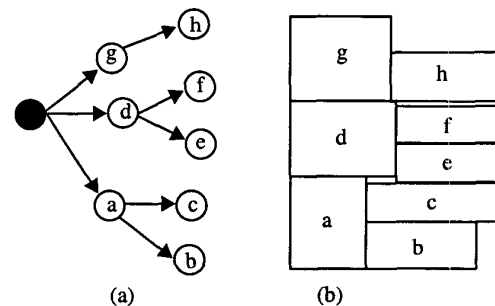

Figure 1: An O-tree and its corresponding block placement

3. RECTANGLE PACKING WITH SYMMETRY CONSTRAINTS IN THE CONTEXT OF THE O-TREE REPRESENTATION

Symmetry constraints can be formulated in terms of *symmetry pairs* and *symmetry groups*. A *symmetry pair* is a couple of blocks having the same dimensions, which have to be placed symmetrically with respect to an axis. A *symmetry group* is a set of symmetry pairs which share a common axis. Assuming the common axes are horizontal in all symmetry groups, then the symmetry constraints can be formulated as follows: if $\{(a_1, b_1), (a_2, b_2), \dots, (a_k, b_k)\}$ is a symmetry group, and (a_i, b_i) is a symmetry pair, for $i=1, \dots, k$ then

$$x_{a_i} = x_{b_i} \tag{1}$$

$$y_{a_i} + y_{b_i} + h_{a_i} = 2y_s \tag{2}$$

where y_s defines the position of the common symmetry axis.

The first type equalities are called *horizontal symmetric constraints*; the second type are *vertical symmetric constraints*.

3.1 Symmetric X-feasible O-trees

If an O-tree can lead to a placement which satisfies both the horizontal positioning constraints and the horizontal symmetric constraints (1), then the O-tree is called *symmetric x-feasible*.

In order to determine whether an O-tree is symmetric x-feasible or not, an horizontal constraint graph G_x is built. This directed graph has the same nodes as the given O-tree, and the same directed edges as horizontal positioning constraints. In addition, for each symmetric pair of blocks (a,b) , two new arcs (a,b) and (b,a) are introduced (unless positioning constraint paths between a and b already exist).

The edges of G_x are weighted: if the edge (u,v) corresponds to a positioning constraint, its weight is $w(u,v)=w_u$, the width of the block represented by node u ; if the edge corresponds to a symmetric constraint, then $w(u,v)=0$.

The existence of positive cycles in the directed graph G_x prevents the symmetric x-feasibility of the O-tree.

Theorem 3.1.1: If the horizontal constraint graph G_x does not contain positive cycles, then the corresponding O-tree is symmetric x-feasible. In addition, one can build a minimum width placement satisfying both horizontal positioning and symmetric constraints in $O(n^2)$ time.

Proof: In a minimum width placement the x-coordinate of each block must be equal to the longest path length from the "root" node to its corresponding node in G_x . Finding a minimum width placement results to be a single-source longest path problem, which can be solved with the Bellman-Ford algorithm [3]. If G_x contains no positive cycles, the longest path problem is provably consistent and the Bellman-Ford algorithm converges.

As the x-coordinates of blocks are longest path lengths, the horizontal positioning constraints being satisfied, the horizontal symmetric constraints (1) are satisfied as well.

The complexity of the Bellman-Ford algorithm is $O(VE)$, where V is the number of nodes and E is the number of edges [3]. Since the O-tree has n edges, the number of edges in G_x is $O(n)$. Taking also into account that G_x has $n+1$ nodes, the complexity results to be $O(n^2)$.

Remark: The proof of Theorem 3.1.1 relies on the Bellman-Ford algorithm [3]. In practice, it is possible to exploit the special structure of the O-tree and perform the same tasks in linear time. The use of Bellman-Ford algorithm in the proof of Theorem 3.1.1 is due only to clarity reasons.

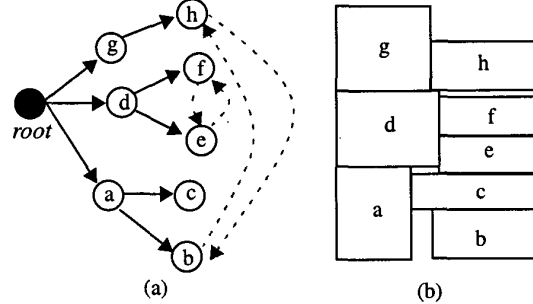

Figure 2: A symmetric x-feasible O-tree and its placement

Example: Assuming the pairs of blocks (b,h) and (e,f) are symmetric, the horizontal constraint graph G_x of the O-tree displayed in Figure 1(a) can be visualized in Figure 2(a), where the broken arcs model the horizontal symmetric constraints (1). Figure 2(b) displays the minimum width placement.

Theorem 3.1.2: If there is a positive cycle in G_x , then the O-tree is not symmetric x-feasible.

Proof: If G_x contains a positive cycle, this cycle must include at least one newly added edge between nodes corresponding to symmetric blocks. If (a,b) is such a directed edge of zero weight, it follows that $x_a > x_b$, as there is a path of positive length from b to a formed by all the edges of the given positive cycle, excepting (a,b) . It follows that the O-tree is not symmetric x-feasible and the horizontal symmetric constraints conflict with the O-tree constraints.

Theorems 3.1.1 and 3.1.2 prove the equivalence between the existence of positive cycles in the horizontal constraint graph G_x and the O-tree property of symmetric x-feasibility.

3.2 Symmetric Y-feasible O-trees

If an O-tree can lead to a placement which satisfies the vertical symmetric constraints (2) and, at the same time, which does not violate the vertical positioning constraints (see Section 2), then the O-tree is called *symmetric y-feasible*.

In order to determine whether an O-tree is symmetric y-feasible or not, we construct a vertical constraint graph G_y .

This directed graph has the same nodes as the given O-tree. Part of the directed edges represent the positioning vertical constraints of the O-tree. These edges can be determined as follows:

for each block $B_i, i=1, \dots, n$, let $\psi(i)$ be the set of block indexes k lower than i in permutation π , which spanning intervals $(x_k, x_k + w_k)$ overlap $(x_i, x_i + w_i)$; if $\psi(i)$ is non-empty, for each $k \in \psi(i)$ introduce in graph G_y a directed edge (B_k, B_i) , unless there is no other edge (B_k, B_j) , with $j \in \psi(i)$ (in order to disregard unnecessary transitive arcs). In order to handle the vertical symmetric constraints (2), for each edge (B_k, B_i) , we define the weight as $(h_k + h_i)/2$. In this way, the nodes will correspond to the center of the blocks rather than the bottom of the blocks. Additional edges modeling the vertical symmetric constraints (2) must be added in G_y as well. Assum-

ing that all the symmetry pairs (a,b) have their elements in topological order relative to the positioning constraints, the additional edges are introduced as follows:

for every symmetry group $\{(a_1, b_1), (a_2, b_2), \dots, (a_k, b_k)\}$

for every two symmetry pairs $(a_i, b_i), (a_j, b_j)$

if there is a path from a_i to a_j then {

add to G_y a directed edge (b_j, b_i) , unless it exists already

let $\text{weight}(b_j, b_i) = \text{the longest path length from } a_i \text{ to } a_j$

if there is a path from b_i to b_j then {

add to G_y a directed edge (a_j, a_i) , unless it exists already

let $\text{weight}(a_j, a_i) = \text{the longest path length from } b_i \text{ to } b_j$

Example: Assuming the pairs of blocks (b,h) and (e,f) are symmetric, the vertical constraint graph G_y of the O-tree displayed in Figure 1(a) can be visualized in Figure 3(a). The plain arcs represent the O-tree vertical positioning constraints. The broken arc (b,e) was introduced during the execution of the procedure shown above, as there was a path from node f to node h . This arc was added to model the vertical symmetry constraints, as it will be explained in the proof of Theorem 3.2.1.

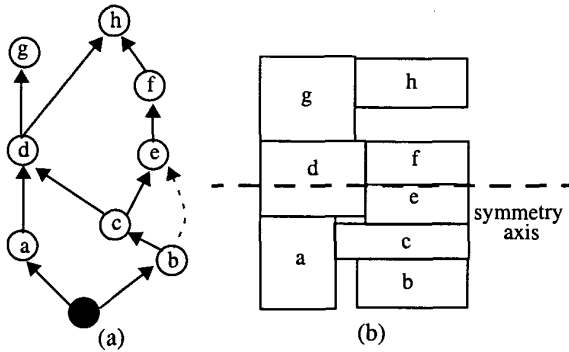

Figure 3: A symmetric y-feasible O-tree and its placement

The existence of cycles in the directed graph G_y prevents the symmetric y-feasibility of the O-tree.

Theorem 3.2.1: If the vertical constraint graph G_y does not contain cycles, then the corresponding O-tree is symmetric y-feasible. In addition, one can build a minimum height placement satisfying both vertical positioning and symmetric constraints in $O(n^2)$ time.

Proof: Denoting x_i, y_i the coordinates of the left-bottom corner of block B_i , $z_i = y_i + h_i/2$ the y-position of the center of B_i and given a symmetry group $U = \{(a_1, b_1), (a_2, b_2), \dots, (a_k, b_k)\}$, a placement which has the properties stated in Theorem 3.2.1 can be constructed as follows:

- (1) let $z_{root} = 0$ and z_i is the longest path length from root to node B_i .
- (2) determine the position of the common symmetry axis

$$y_s = \max_{(a_i, b_i) \in U} \left\{ \frac{z_{a_i} + z_{b_i}}{2} \right\}$$

- (3) execute a topological sort of the nodes in G_y , reorder the symmetry pairs (a_i, b_i) in U such that nodes b_i are ordered according to the topological sort

- (4) for each symmetry pair (a_i, b_i) in U

$$\text{let } d = y_s - \frac{z_{a_i} + z_{b_i}}{2}$$

if $d > 0$ then {

update $z_{b_i} = z_{b_i} + d$

execute the Bellman-Ford single-source longest path algorithm [3], considering node b_i as the source }

Since the y-positions of the blocks are adjusted (Step 4) according to the topological order, the y-positions of the early symmetry pairs are not affected by the adjustments involving symmetry pairs processed later. After each iteration in Step 4, the current pair (a_i, b_i) will get y-coordinates of block centers symmetric relative to the position y_s of the common axis. One by one, all vertical symmetric constraints are satisfied. Taking into account that the vertical constraint graph G_y was built such that the positioning constraints are inherently satisfied, the O-tree results to be symmetric y-feasible. As the position y_s of the symmetry axis has the minimum possible value, the final placement has a minimum height.

Steps 1 and 4 contain the most expensive operations. Due to the Bellman-Ford algorithm, step 1 requires $O(n^2)$ time [3]. Step 4 has k iterations; in each iteration the single-source longest path algorithm may be executed. Actually, each edge in G_y is examined no more than once and, therefore, the complexity is $O(n^2)$. In conclusion, the algorithm described above runs in $O(n^2)$ time.

Theorem 3.2.2: If there is a cycle in G_y , then the O-tree is not symmetric y-feasible.

Proof: For every symmetry pair (a,b) , as we may assume $x_a = x_b$, there is a path between the nodes a and b containing only edges corresponding to positioning constraints. Let (a,b) and (c,d) be two symmetry pairs belonging to the same group, and suppose there is such a path from a to b and another one from c to d . A cycle in G_y must contain a "broken" arc (corresponding to a vertical symmetric constraint), as the positioning constraints determine an acyclic graph. Let (d,b) be such a "broken" arc contained in a cycle: it follows there is a path from node b to node d in G_y and, consequently, $z_d > z_b$. But this "broken" arc (d,b) could be introduced in G_y only due to the existence of a path from node a to node c . This implies $z_c > z_a$, which together with the other inequality $z_d > z_b$, implies that the symmetry pairs cannot have a common symmetry axis (as $(z_c + z_d)/2 > (z_a + z_b)/2$), which contradicts the symmetry group assumption.

3.3 Symmetric Feasible O-trees

An O-tree is called *symmetric feasible* if it is both symmetric x- and y-feasible. Given n rectangular blocks, a set of symmetric constraints, and a symmetric feasible O-tree, one can build a minimum area placement as described in subsections 3.1 and 3.2, where the positions of the blocks satisfy both the O-tree constraints and the given symmetric constraints. On the other hand, there is a reciprocal property:

Theorem 3.3.1: A minimum area rectangle packing with symmetric constraints can be represented by a symmetric feasible O-tree.

Our placement tool employs the simulated annealing algorithm as the exploration engine for the O-tree search space. According to theorem 3.3.1, only the symmetric feasible O-trees are taken into account, as they lead to placement configurations satisfying the symmetric constraints. The test of symmetric feasibility and the placement construction can be done simultaneously.

4. EXPERIMENTS

The placement algorithm described in this paper has been implemented in C on a SUN ULTRA-60 workstation.

Table 1 displays the placement results obtained from several test cases. SP denotes symmetry pairs, SS denotes self-symmetric cells. The self-symmetric cells are cells presenting geometrical symmetry and sharing the same (horizontal) axis with the other symmetry pairs in the group. The smallest example having 14 cells runs in 10 seconds, while the largest example - with 110 cells - has been successfully placed in about 25 minutes.

Figure 4 shows the block placement of a circuit containing a symmetry group, consisting of 3 pairs of symmetric devices and 2 self-symmetric cells, which can be noticed near the bottom of the figure. The 47 block example has been processed in 4.37 minutes. The layout area is only about 12% larger than the total area of all the blocks in the circuit, which proves the good rectangle packing capability of the placement tool.

Figure 5 shows the layout (after placement) of another circuit characterized by a larger number of symmetric constraints. Our placement tool has processed this example (having 11 symmetry pairs and 1 self-symmetric cell) in only 5.21 minutes. The speed exhibited by the tool can be justified as follows: the upper-bound of the number of configurations in the O-tree representation [4] is smaller than the upper-bounds in other topological representations.

Our experiments suggest that the speed performance of our placement tool based on the O-tree representation is better relative to similar tools where placement configurations are represented employing absolute coordinates [5], or tools based on the sequence-pair topological representation [1].

5. CONCLUSIONS

This paper has addressed the problem of taking into account symmetry constraints when non-slicing floorplans are represented with O-tree structures. The necessity of handling symmetry emerges when, for instance, the O-tree topological representation is applied to device-level placement for analog layout. The good performance of our ordered tree-based placement tool when dealing with several analog designs taken from industry substantiates the effectiveness of our novel techniques.

6. REFERENCES

- [1] F. Balasa, K. Lampaert, "Module Placement for Analog Layout Using the Sequence-Pair Representation," *Proc. 36th DAC.*, pp. 274-279, June 1999.
- [2] J. Cohn, D. Garrod, R. Rutenbar, L. Carley, "KOAN/ANGRAM II: new tools for device-level analog layout," *IEEE J. of solid State Circuits*, Vol. SC-26, No. 3, pp. 330-342, March 1991.
- [3] T. H. Cormen, C. E. Leiserson, R. L. Rivest, "Introduction to Algorithm," *The MIT press*, 1990.
- [4] P.-N. Guo, C.-K. Cheng, T. Yoshimura, "An O-tree representation of non-slicing floorplan and its applications," *Proc. 36th DAC.*, pp. 268-273, June 1999.
- [5] K. Lampaert, G. Gielen, W. Sansen, "A performance-driven placement tool for analog integrated circuits," *IEEE J. of Solid-State Circuits*, Vol. SC-30, No. 7, pp. 773-780, July 1995.
- [6] E. Malavasi, E. Charbon, E. Felt, A. Sangiovanni-Vincentelli, "Automation of IC layout with analog constraints," *IEEE Trans.*

Table 1: Placement results

Design	# of cells	Sym. const.	Area (μm^2)	Time (min)
vd2	14	2 SP	1365	0.17
dffrsdch	37	4 SP	6286	1.89
tx_current	47	3 SP, 1 SS	46309	4.73
lpf2_b25b	52	11 SP, 1 SS	36245	5.21
dcservo_cmfb	66	3 SP, 3 SS	60466	11.43
biasynth2p4g	67	8 SP	4967	13.54
lnamixbias2p4	110	4 SP	49027	24.36

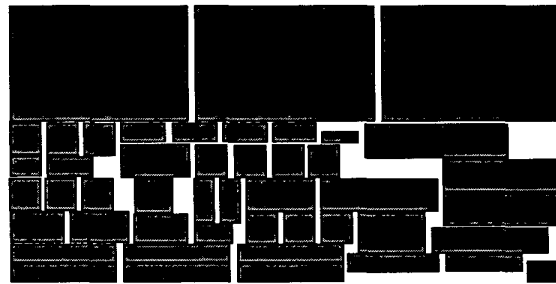

Figure 4: Design *tx_current* with 47 cells

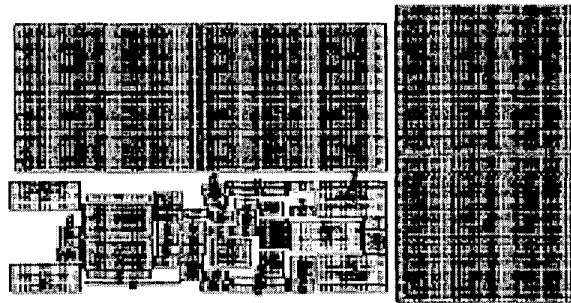

Figure 5: Design *lpf2_b25b* with 52 cells

- on *Comp.-Aided Design of IC's and Systems*, Vol. 15, No. 12, pp. 1518-1524, Dec. 1996.
- [7] E. Malavasi, E. Charbon, G. Jusuf, R. Totaro, A. Sangiovanni-Vincentelli, "Virtual symmetry axes for the layout of analog IC's," *Proc. 2nd ICVC*, pp. 195-198, Seoul, Korea, Oct. 1991.
- [8] H. Murata, K. Fujiyoshi, S. Nakatake, Y. Kajitani, "VLSI module placement based on rectangle-packing by the sequence-pair," *IEEE Trans. on Comp.-Aided Design of IC's and Systems*, Vol. 15, No. 12, pp. 1518-1524, Dec. 1996.
- [9] J. Rijmenants, J.B Litsios, T.R. Schwarz, M. Degrauwe, "ILAC: an automated layout tool for analog CMOS Circuits," *IEEE J. of Solid-State Circuits*, Vol. SC-24, No. 2, pp.417-425, April 1989.