

Demo: WiFlow - Real Time Travel Time Estimation Using Wi-Fi Monitors

A.B.M. Musa
Department of Computer Science
University of Illinois at Chicago
Chicago, IL 60607, USA
amusa2@uic.edu

Jakob Eriksson *
Department of Computer Science
University of Illinois at Chicago
Chicago, IL 60607, USA
jakob@uic.edu

Abstract

A real-time travel time estimation system is demonstrated that uses Wi-Fi monitors deployed along surface streets to capture Wi-Fi packets from smartphones in passing vehicles. Travel time is estimated based on observations of the same vehicle by two or more monitors.

Categories and Subject Descriptors

H.4.2 [Information Systems Applications]: Types of Systems—*Logistics*

General Terms

Algorithms, Design, Experimentation, Measurement

Keywords

Traffic Speed, Travel Time, Smartphone, Wi-Fi

1 Introduction

Real time travel time estimation is an important service to commuters for travel planning, congestion avoidance, and cost saving. However, existing systems [1, 2, 3] for travel time estimation offer limited coverage (mostly highways), are very costly, or are insufficiently accurate. In this demo, we will demonstrate WiFlow, a low cost travel time estimation system that combines inexpensive Wi-Fi monitors with statistical processing to estimate travel times on city streets.

2 Deployment and Data Collection

Real-time travel time estimation over a large area or at city scale requires deployment of many sensor nodes and continuous data transmission from these nodes. WiFlow uses off-the-shelf Wi-Fi routers as monitors and a custom sensor firmware to capture and transmit a very small amount

*This material is based upon work supported by the National Science Foundation under Grant CNS-1017877.

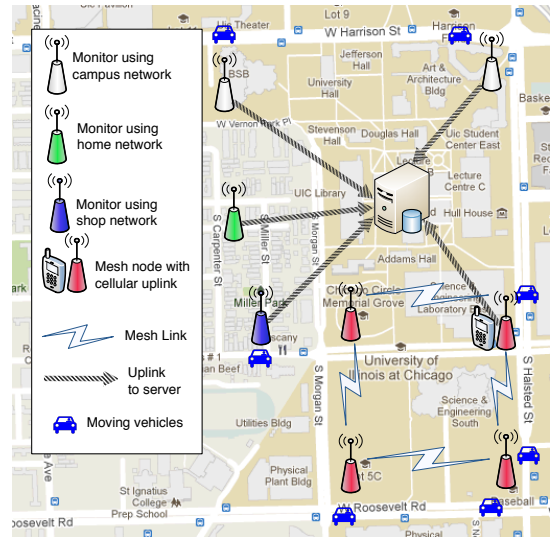
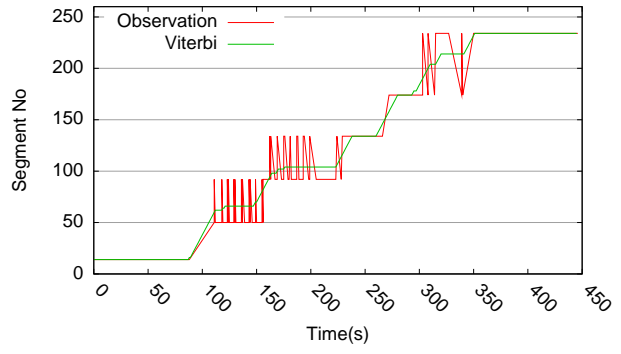
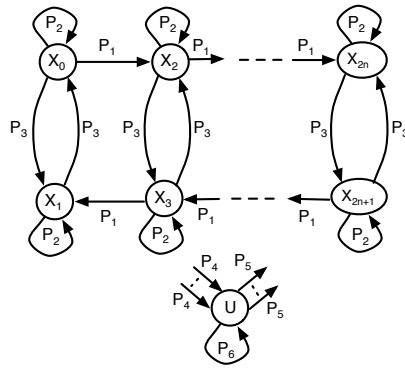

Figure 1. Our Wi-Fi monitors use our campus wireless network, home or business networks, or mesh with cellular uplink to upload data to a central server.

of data (approx. 100 KB per hour). We use three different methods of deployment. First, we have deployed nodes along the streets near the UIC campus as shown in Figure 1 and we are using the UIC wireless network to upload the data to the server. Second, we have deployed nodes in shops and houses located nearby the streets of interest and we are using their respective wireless networks to upload the data. Third, where no infrastructure is available, we deploy battery-powered nodes with a mesh network among them and single cellular uplink for real-time transmission of data to the server. The WiFlow deployment architecture is shown in Figure 1.

Using little bandwidth is important because of our use of household Wi-Fi networks and cellular uplinks. We also need to limit local resource consumption due to hardware constraints. In a typical scenario, there is a lot of Wi-Fi activity in city areas. Capturing and retaining all observed packets will result in a very large amount of data. To reduce data storage and transmission demand, we only retain aggregates of relevant data. We also attempt to retain and transmit data from moving vehicles only. Figure 2 shows the local processing pipeline in the Wi-Fi monitor.



(a) Street is divided into small directed segment-states.

(b) Transition states of the hidden Markov model. An "unknown state" represents streets not explicitly included in the model.

(c) Viterbi output showing optimal position (in terms of road segments) of a vehicle over time.

Figure 3. Hidden Markov Model and Viterbi Output

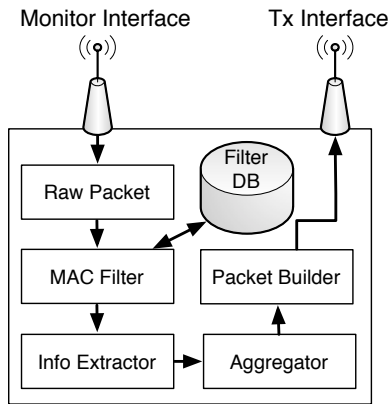

Figure 2. Local Processing at Wi-Fi Monitor.

3 Data Processing

Intuitively, one can calculate the speed of a vehicle based on the time between successive observations. However, several complexities arise in a real-world system.

1. The relatively long range of Wi-Fi, and the unknown nature of the transmission path results in poor positional accuracy of vehicle detections. This may contribute significant error to the resulting travel time estimates.
2. Vehicles may be parked for some time between successive observations, making travel times appear longer than they really are.
3. Packets received from pedestrians and bicyclists may be mixed in with those from vehicles, introducing additional measurement error.

To address (1) and (2), we model the road network using a hidden Markov model (Figure 3(a)-(b)) and apply the Viterbi algorithm to find most probable sequence of vehicle positions over time. Figure 3(c) shows the output from the Viterbi algorithm representing estimated vehicle position. Finally, to distinguish pedestrians from vehicles, we apply a clustering algorithm, and compute travel times from members of the vehicle cluster only.

4 The Demonstration

We will perform a live demonstration of the WiFlow system showing real-time speed estimates. In particular, we will demonstrate the following:

- **Real-time speed measurement:** We will demonstrate live travel time estimation using WiFlow on streets nearby the UIC campus. We may also set up temporary sensors and demonstrate live travel time estimation on streets nearby the conference venue.
- **Data Collection Methods:** Data collection techniques using a combination of campus network, household networks and mesh networks will be demonstrated. We will describe the techniques used for compact data logging and transmission.
- **Data processing:** We will describe the processing of raw monitor data to produce travel time estimates.
- **Hardware show and tell:** We will show example hardware used in the WiFlow system.

5 References

- [1] M. Hamed, R. Fish, and A. Haghani. Data collection of freeway travel time ground truth with bluetooth sensors. In *Transportation Research Record: Journal of the Transportation Research Board*, volume 2160, pages 60–68, 2010.
- [2] K. Kwong, R. Kavalier, R. Rajagopal, and P. Varaiya. Real-time measurement of link vehicle count and travel time in a road network. *Intell. Transport. Sys.*, 11:814–825, Dec 2010.
- [3] M.Ndoye, V. Totten, B. Carter, D. Bullock, and J. Krogmeier. Vehicle detector signature processing and vehicle reidentification for travel time estimation. In *Proceedings of 88th Transportation Research Board Annual Meeting*, 2008.